

LESSO

Residential Off-grid Smart Energy Solutions



Intelligent Storage for Smart Living

Ver. 2026.05

INTELLIGENT STORAGE FOR SMART LIVING



SAFETY

The battery system complies with multiple key international standards – UN38.3, MSDS, etc.



EFFICIENCY

MPPT efficiency **>99%**, PV efficiency **>96%**, system efficiency up to **95%**.



DURABILITY

Module warranty **30** years, system design life **>15** years.



RELIABILITY

Grid/solar/battery switching time **<10** ms for an uninterrupted experience.



FLEXIBLE

Requires only **4.5** m²/kW for module installation, fitting different installation scenarios easily.

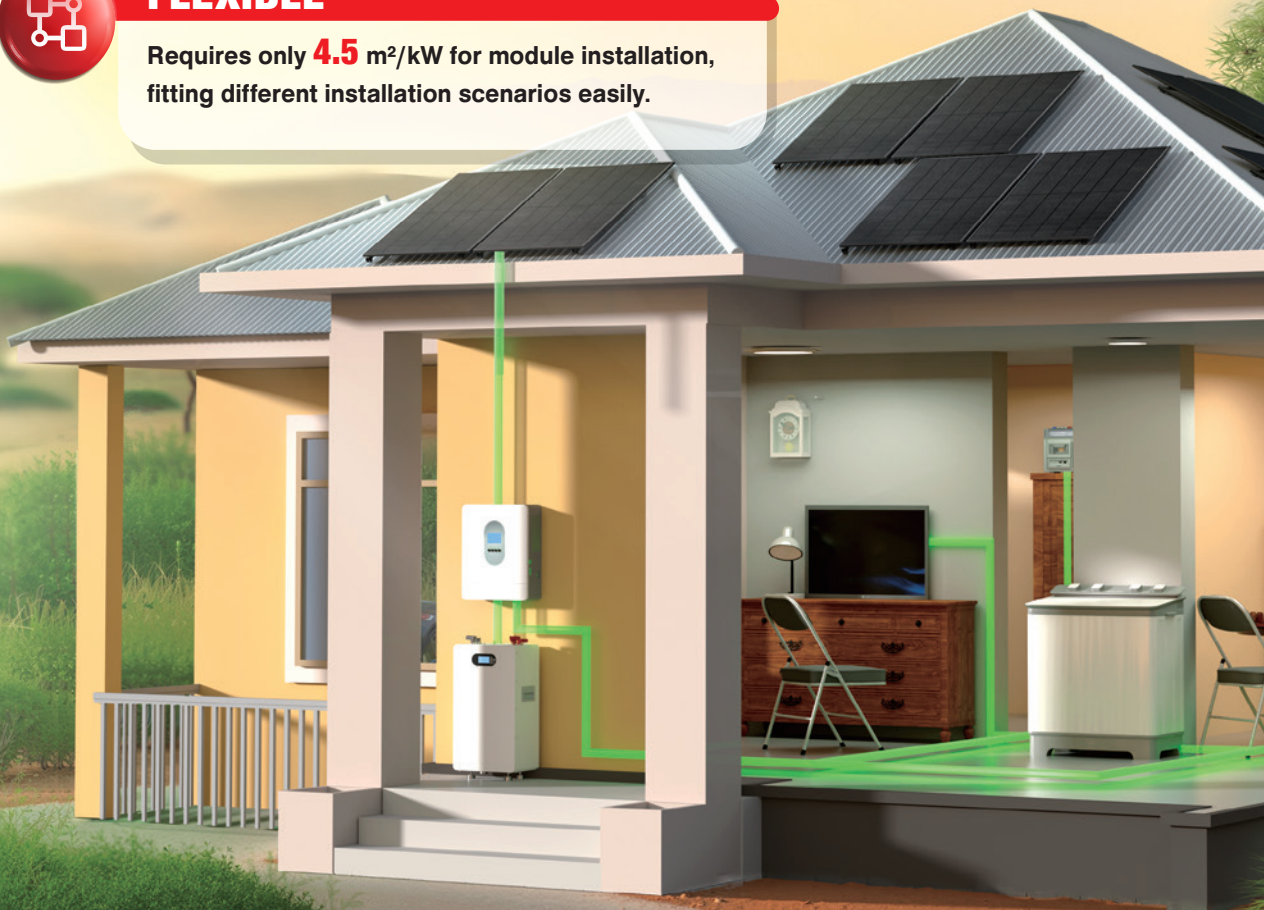

1.5kW Single Phase Off-grid Solar Energy Solution



Powers home essentials: lighting, charging, fans, small appliances.



Output: 4kWh/day, supports basic loads for 8-12 hours.



Simple & quick setup, ready to use fast.

Schematic Diagram

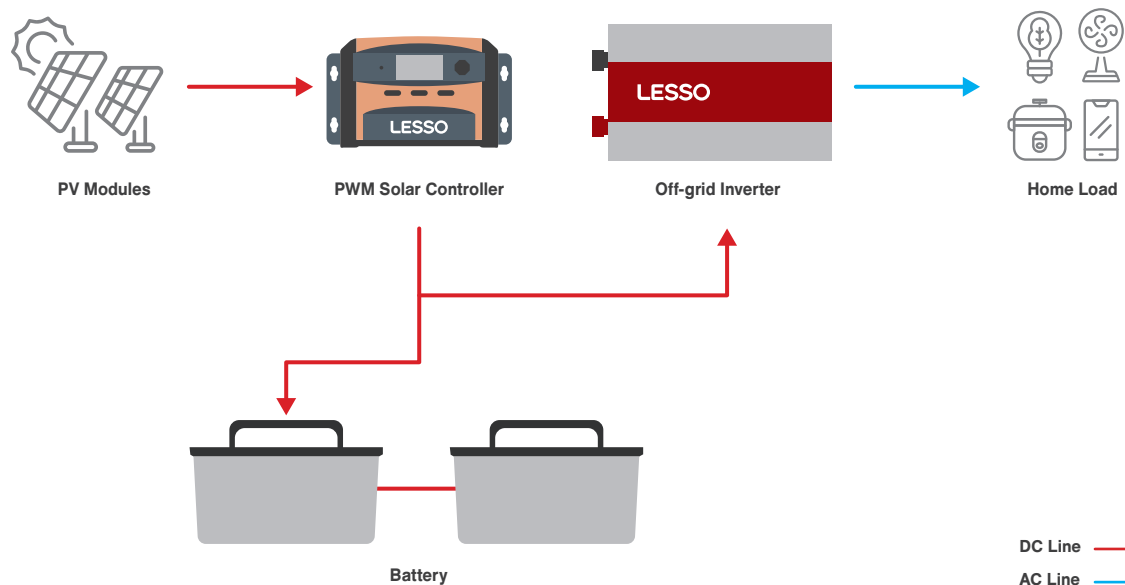

System Configuration

	1.5kW+2.4kWh
AC Output Type	Single phase 230Vac L-N
PV Capacity	450Wp x 2pcs
Daily Average Energy Production (5h)	4kWh
PV Installation Footprint	> 4m ²
Energy Storage Capacity	12V / 100Ah x2
PWM / Inverter	PWM: 40A Inverter: 1.5kW
BOS (optional)	PV cable, Battery cable, AC cable, Circuit breakers

* The daily average available energy production is calculated based on 90% of the total power of PV modules.

* Remark: Specifications are subject to change without notice.

4kW Single Phase Off-grid Solar Energy Solution



All-day electricity for medium households.



Output: 17kWh/day, 24-hour uninterrupted power for home appliances.



No blackout, smart auto-switch between solar/grid/battery.

Schematic Diagram

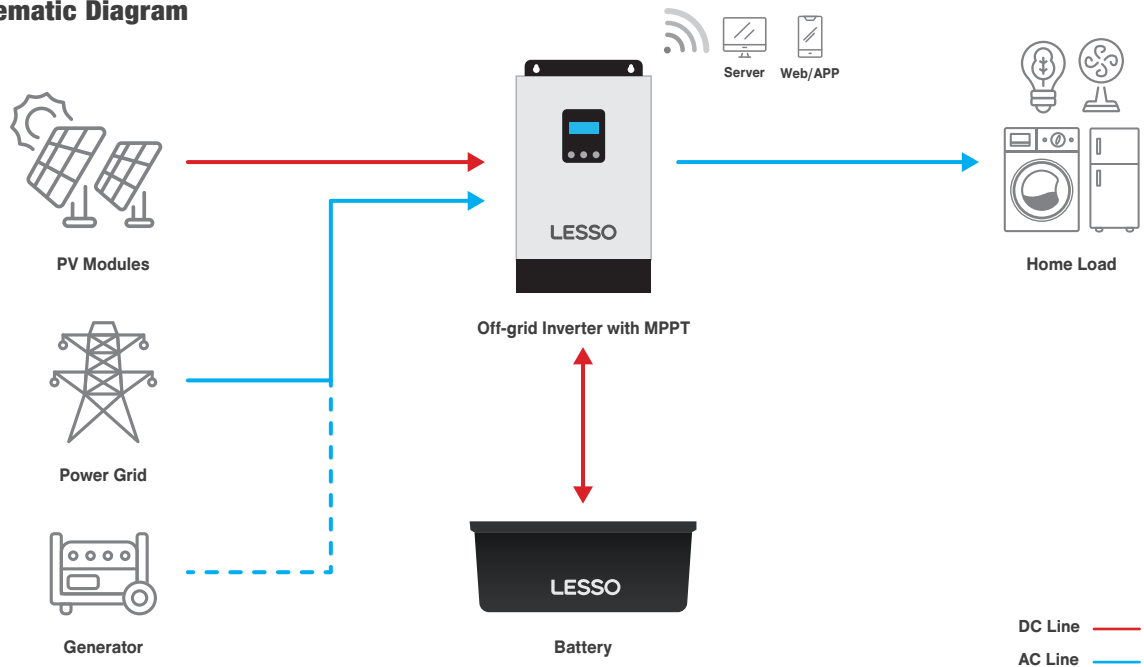

System Configuration

	4kW+3.84kWh
AC Output Type	Single phase 220/230/240Vac L-N
PV Capacity	635Wp x 6pcs
Daily Average Energy Production (5h)	17kWh
PV Installation Footprint	> 18m ²
Energy Storage Capacity	25.6V / 200Ah / 3.84kWh
Inverter	4kW
BOS (optional)	PV cable, Battery cable, AC cable, Distribution box

* The battery distribution box can be expanded to accommodate one additional set of batteries of the same capacity.

* The daily average available energy production is calculated based on 90% of the total power of PV modules.

* Remark: Specifications are subject to change without notice.

6.2kW Single Phase Off-grid Solar Energy Solution



For high-power needs: air conditioners, water pumps.



Output: 22kWh/day, 6-10 hours for key equipment.



Strong output & modular battery for easy capacity expansion.

Schematic Diagram

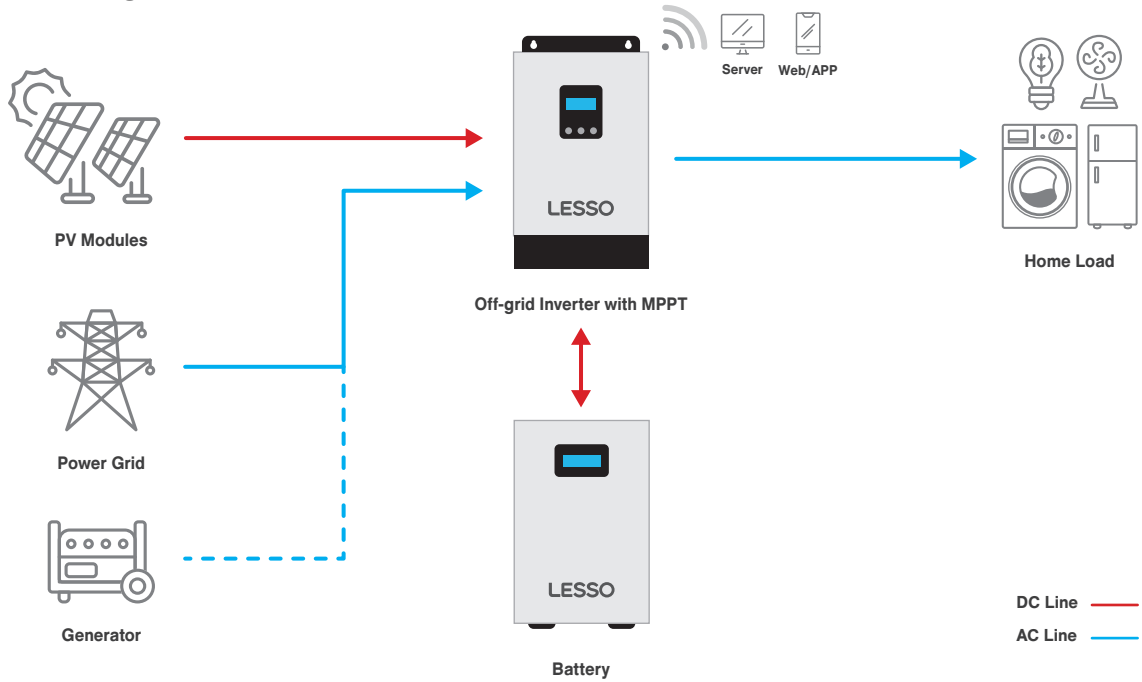

System Configuration

	6.2kW+10.49kWh
AC Output Type	Single phase 220/230/240Vac L-N
PV Capacity	635Wp x 8pcs
Daily Average Energy Production (5h)	22kWh
PV Installation Footprint	> 24m ²
Energy Storage Capacity	51.2V / 205Ah / 10.49kWh
Inverter	6.2kW
BOS (optional)	PV cable, Battery cable, AC cable, Distribution box

* The battery distribution box can be expanded to accommodate one additional set of batteries of the same capacity.

* The daily average available energy production is calculated based on 90% of the total power of PV modules.

* Remark: Specifications are subject to change without notice.

6.2kW Single Phase Hybrid Solar Energy Solution



For all-day power use:
AC, heating,
EV charging.



Output: 40kWh/day,
supports whole-house
backup.



Grid-tied efficiency &
modular battery for smart
energy management.

Schematic Diagram

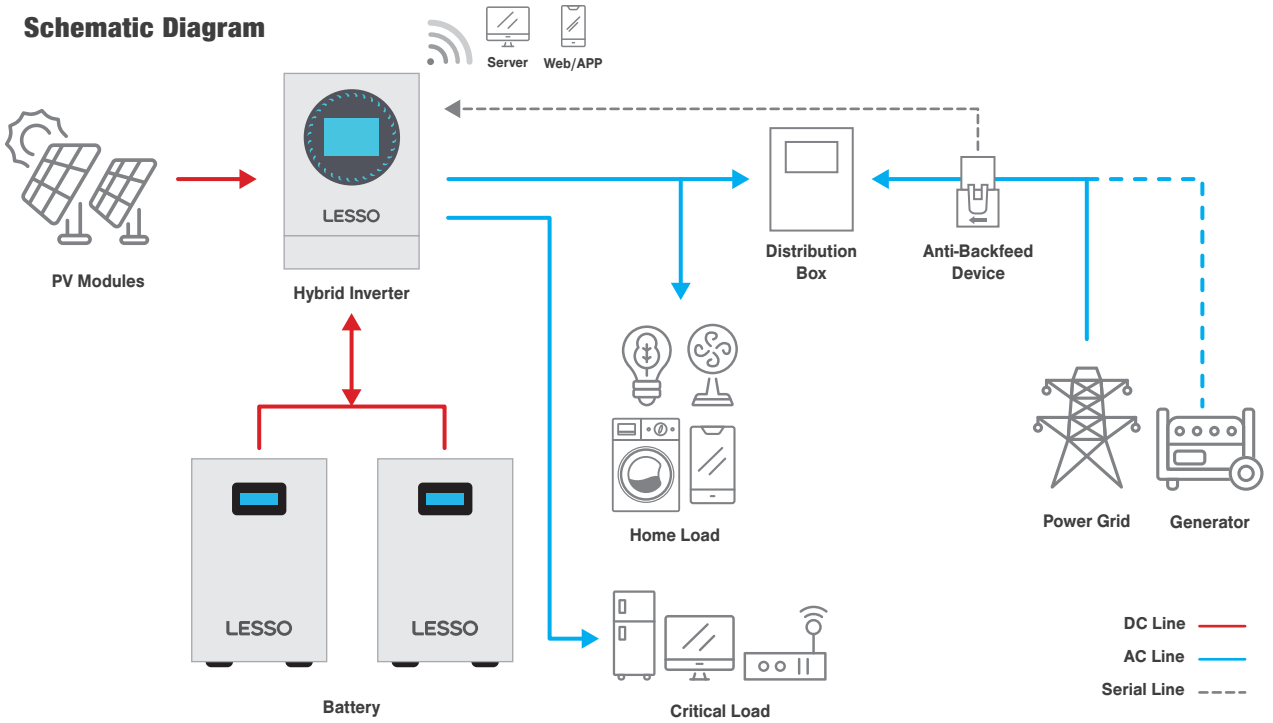

System Configuration

	6.2kW+20.98kWh
AC Output Type	Single phase 220/230Vac L-N
PV Capacity	635Wp x 14pcs
Daily Average Energy Production (5h)	40kWh
PV Installation Footprint	> 52m ²
Energy Storage Capacity	51.2V / 205Ah / 10.49kWh x2
Inverter	6.2kW
BOS (optional)	PV cable, Battery cable, AC cable, Distribution box

* The daily average available energy production is calculated based on 90% of the total power of PV modules.

* Remark: Specifications are subject to change without notice.

12.4kW Single Phase Off-grid Solar Energy Solution



For Ideal for large, high-consumption households.



Output: 45kWh/day, Power all appliances simultaneously.



Achieve year-round reliable energy independence.

Schematic Diagram

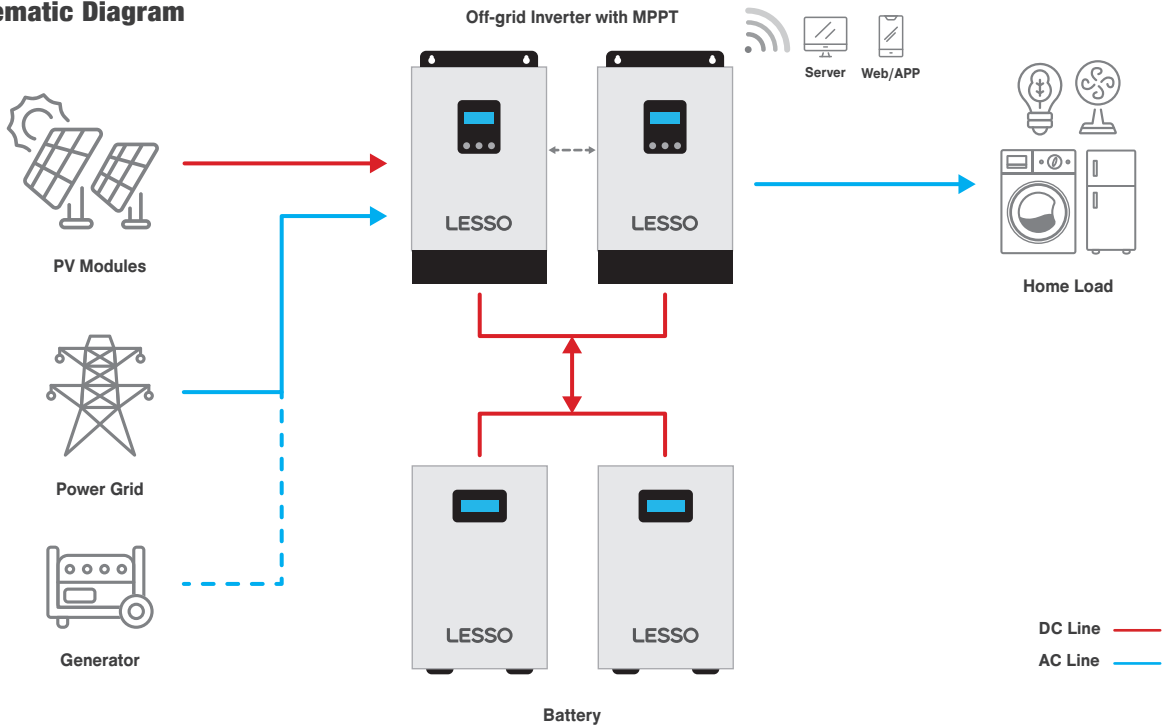

System Configuration

	12.4kW+20.98kWh
AC Output Type	Single phase 220/230/240Vac L-N
PV Capacity	635Wp x 16pcs
Daily Average Energy Production (5h)	45kWh
PV Installation Footprint	> 48m ²
Energy Storage Capacity	51.2V / 205Ah / 10.49kWh x2
Inverter	6.2kW x2
BOS (optional)	PV cable, Battery cable, AC cable, Distribution box

* The daily average available energy production is calculated based on 90% of the total power of PV modules.

* Remark: Specifications are subject to change without notice.

18.6kW Three Phase Off-grid Solar Energy Solution



Ideal for large homes/villas with three-phase supply.



Output: 68kWh/day, runs high-power appliances (e.g., electric stoves) for long periods.



Supports unbalanced 3-phase loads, better compatibility.

Schematic Diagram

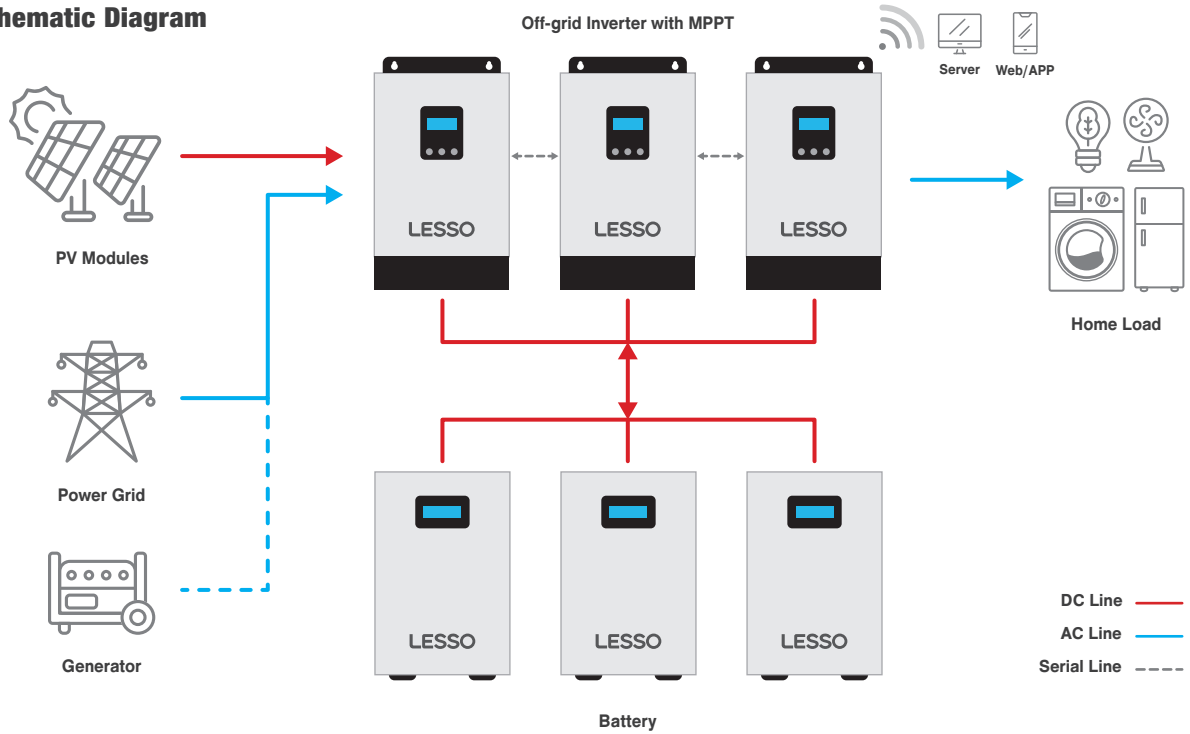

System Configuration

	18.6kW+31.47kWh
AC Output Type	Three phase 380/400Vac L1-L2-L3-N
PV Capacity	635Wp x 24pcs
Daily Average Energy Production (5h)	68kWh
PV Installation Footprint	> 72m ²
Energy Storage Capacity	51.2V / 205Ah / 10.49kWh x3
Inverter	6.2kW x3
BOS (optional)	PV cable, Battery cable, AC cable, Distribution box

* The daily average available energy production is calculated based on 90% of the total power of PV modules.

* Remark: Specifications are subject to change without notice.

Product Specifications

450C(HBD)54(182)

182 N-TOPCon dual-glass bifacial PV module

Solar cell type: 182mm N-TOPCon Mono Cell (Half cell)

Solar cell arrangement: 108pcs(6x18)

Max power: 450W

Max efficiency: 23.04%

Dimension: 1722x1134x30mm

Weight: 23.1kg



635C(HBD)66(210R)

210R N-TOPCon dual-glass bifacial PV module

Solar cell type: 210R N-TOPCon Mono Cell (Half cell)

Solar cell arrangement: 132pcs(6x22)

Max power: 635W

Max efficiency: 23.51%

Dimension: 2382x1134x30mm

Weight: 32.5kg



LET-B40KN1E1

PWM-controlled PV DC-DC converter

DC Output Voltage: 24Vdc

PV Input Voltage: 12-54Vdc



LGC-152BLP2

Off-grid inverter

Rated power: 1.5kW

DC input voltage: 24Vdc

Output voltage: 230Vac

Output type: Single phase modified sine wave



DJM12100

Low voltage battery

Rated voltage: 12V

Nominal capacity: 100Ah

Battery type: Lead acid battery



LES-402A2AF-TF

Off-grid inverter with MPPT

Rated power: 4kW

DC input voltage: 24Vdc

Output voltage: 220/230/240Vac

Output type: Single phase



LES-622A4BF-TF

Off-grid inverter with MPPT

Rated power: 6.2kW

DC input voltage: 48Vdc

Output voltage: 220/230/240Vac

Output type: Single phase



LEC-622A4B2F2-TF

Hybrid inverter

Rated power: 6.2kW

DC input voltage: 48Vdc

Output voltage: 220/230/240Vac

Output type: Single phase

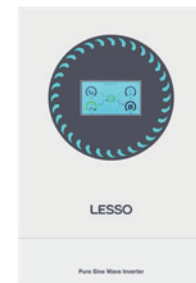

LSM025.6V200AH-B01

Low voltage battery

Nominal voltage: 25.6V

Nominal capacity: 200Ah

Nominal energy: 3.84kWh

Battery type: LiFePO₄ battery



LSRW51V205AH-LFP

Low voltage battery

Nominal voltage: 51.2Vdc

Nominal capacity: 205Ah

Nominal energy: 10.49kWh

Battery type: LiFePO₄ battery



Guangdong Lesso Energy Storage Technology Co., Ltd

Daba Industrial Area, Longjiang Town, Foshan City, Guangdong Province, China

LESSO Group (2128) is listed in the Stock Exchange of Hong Kong.



www.lessosolar.com



info@lessosolar.com



LESSO Solar